

GERMAN TECHNOLOGY

## **AUTOMATIC TUNNEL PASTEURIZERS AND COOLERS**

- ❖ Bottles and Cans all sizes
- ❖ Beer
- ❖ Milk
- ❖ Soft Drink and Beverages
- ❖ Juices
- ❖ Ketchup

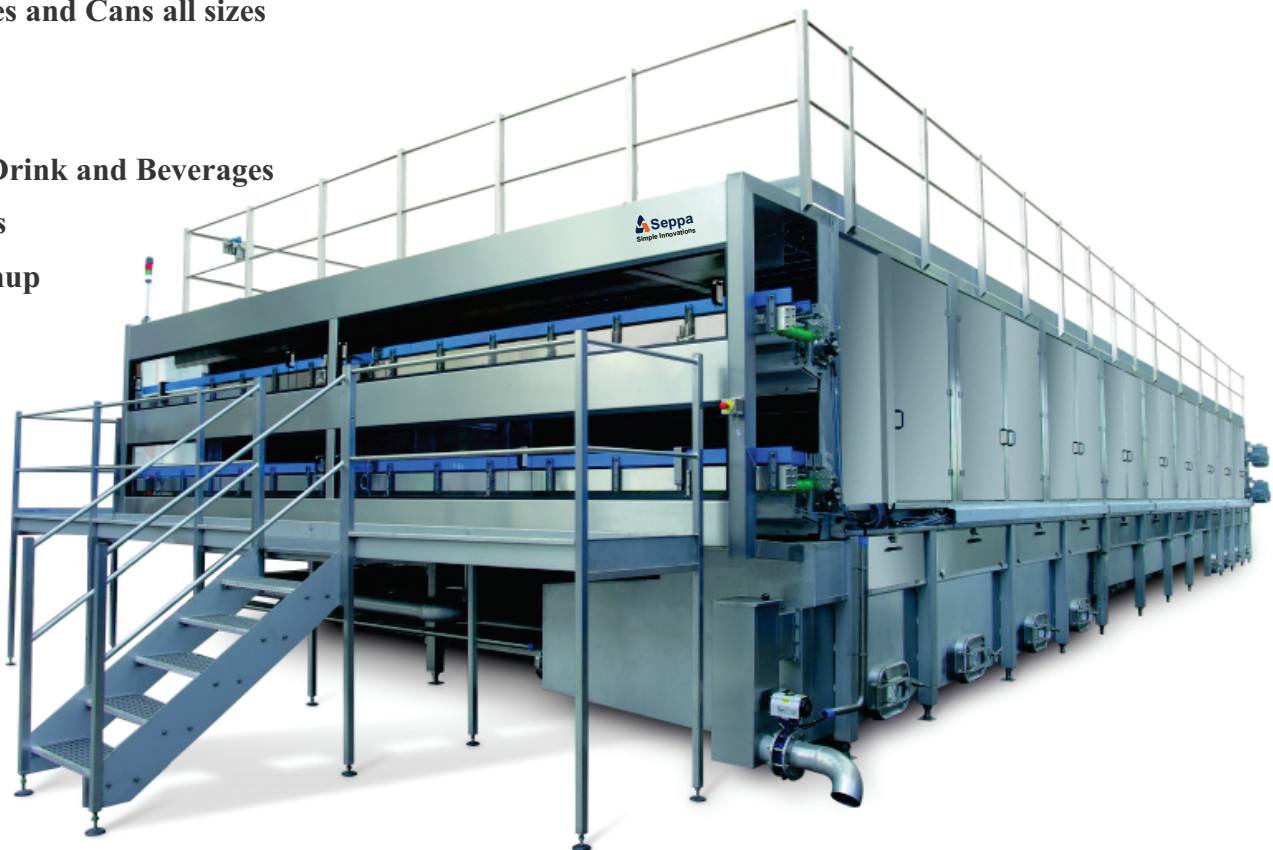

**25** Years of COMPLETE LINE SOLUTIONS

Manufacturers of Automatic Glass Bottling Line  
Joint Venture With Rita Bottling

Seppa - Rita has a Technical Collaboration with M/s. Rita Bottling Machines Private Limited for the manufacture of Pasteurizers and Tunnel Coolers as per their design and Technology.

Seppa - Rita is one of the leading manufacturers of Tunnel Pasteurizers in India and Abroad.

Seppa - Rita has provided significant contribution in Indian and International Breweries where several Seppa - Rita Tunnel Pasteurizers have been installed.

Our designs ensures maximum savings in utilities like water, steam, power and other operational expenses. Engineers and Technicians of Seppa - Rita have been trained by Rita Bottling for the installation, commissioning and maintenance of the machineries.

The end use of the Automatic Tunnel Pasteurizers is to automatically pasteurize (with Heat) the bottled or canned product at the rated speed and quality and thereby make the package stable for several months without any quality deterioration of the food.

The heat system employed in the process kills any micro-organisms, stabilizing and preserving the quality of the foods in its natural state without addition of any harmful chemicals or preservatives. Pasteurized products in cans/bottles stay fresh for consumption for several months.



**Single Deck Series**

- ❖ Quick Heat Transfer
- ❖ Super Heat Zone
- ❖ Defined Pasteurization Units
- ❖ Low Water Consumption
- ❖ Minimum Steam Consumption
- ❖ Economy of Space
- ❖ Energy Saving
- ❖ Stainless Steel In-feed, Out-feed
- ❖ Stainless Steel extra heavy duty flat mesh belt
- ❖ Clog free Stainless Steel Spray Pans
- ❖ Perfect Automatic Temperature Control Panel
- ❖ Fully Automatic Electric and Remote Panels with digital Readout and Printout
- ❖ Modern Pumping System



Dimensions

Model No	SD 80	SD 120	SD 180	SD 210	SD 240
Length (mm)	12700	14700	14700	18000	19000
Width (mm)	4700	4700	8200	8400	8400
Height (mm)	2100	2100	2100	2100	2100

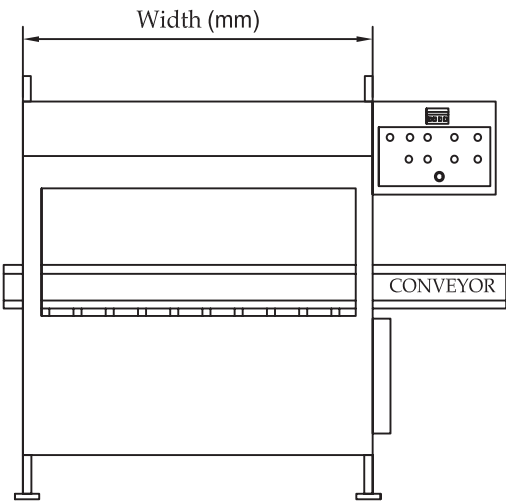
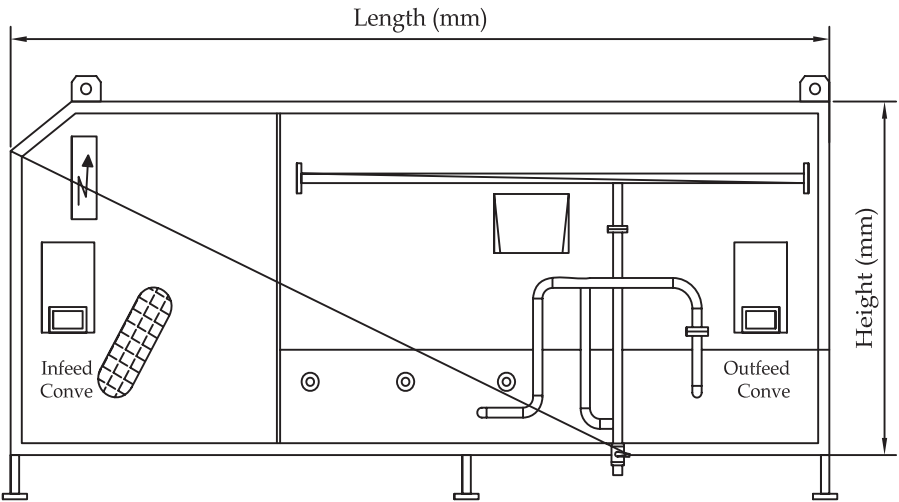

### Single Deck Series

DATA	SD 80	SD 120	SD 180	SD 210	SD 240
650ml (Bottles / Hour)	8000	12000	18000	21000	24000
Steam Consumption (Kg /Hr)	400	600	900	1050	1200
Steam Pressure (Kg / Cm <sup>2</sup> )	4 - 5	4 - 5	5 - 6	5 - 6	5 - 6
Water Consumption (m <sup>3</sup> / Hr)	1	1	2	2	3
Water Pressure	2 Kg / Cm <sup>2</sup>				
Air Consumption (Litres / Hr)	1000	1000	2000	2000	2500
Air Pressure	Max 6 Kg / Cm <sup>2</sup>				
Power (Kw)	20	22	42	45	50
Weight (Tonnes)	22	26	35	42	45

Note : - Due to continuous improvements, specifications are subject to change without notice.

We also manufacture Vacuum Fillers, Pressure Less Combining Conveyors, Bottle Washers, Premix Carbonators, Crate Washers, Cap Conveyors and Other Bottling Equipments.

Step Up  
Productivity  
Hygiene  
And Line Speed

**SeppA**  
Simple Innovations

**SEPPA SOLUTIONS PRIVATE LIMITED**

No. 149, Poonamallee High Road,  
Kilpauk, Chennai - 600 010, India.

Ph : +91-44-2836 9900 - 71, Fax : +91-44-2836 2470,

Toll Free : 1800 425 20000

E-mail : [info@seppasolutions.com](mailto:info@seppasolutions.com)

Website : [www.seppasolutions.com](http://www.seppasolutions.com)